

Поворотные круги SAF

SAF-HOLLAND ball races are components for fitting onto trailers and agricultural vehicles operated on-road.

Please follow the specific trailer manufacturer instructions for the operation of the particular vehicle. Compliance with the corresponding national legislation safety standard is required.



Single Row Ball Races STANDARD MAINTENANCE

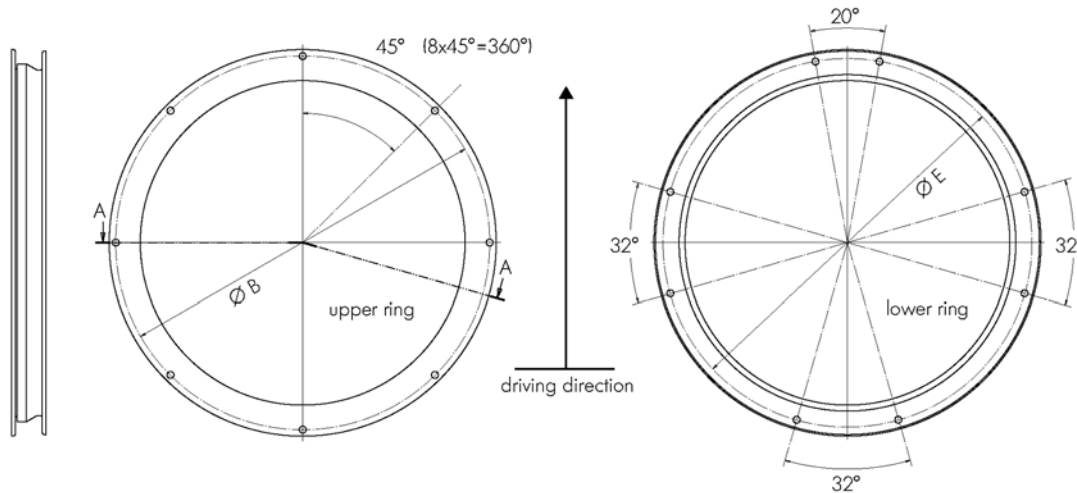
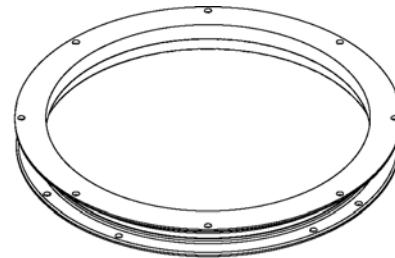
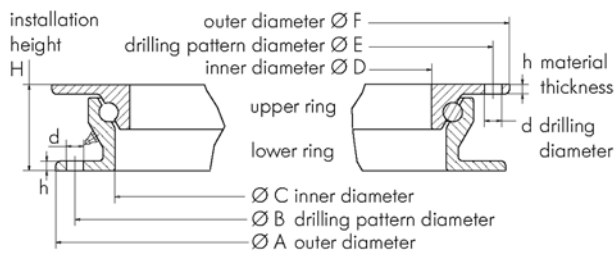

Type	Model	Max. axial load	A	B	C	D	E	F	d	h	H	Weight	Order no.
		t	mm	mm	mm	mm	mm	mm	mm	mm	mm	kg	
BR-S 8	undrilled	8	1000	960	877	846	974	1008	18	10	90	73	662 106 100
BR-S 10	undrilled	10	1000	960	877	846	974	1008	18	10	90	73	662 106 120
BR-S 10-1	drilled	10	1100	1060	977	946	1074	1108	18	10	90	80	662 106 140
BR-S 12-1	drilled	12	1100	1060	977	946	1074	1108	18	10	90	80	662 106 160
BR-S 13-2	drilled	13	1200	1160	1077	1046	1174	1208	18	10	90	87	662 106 180

- 7 lubrication points with grease nipples
- TÜV approved