

Поворотные круги SAF малообслуживаемые, с защитными пыльниками

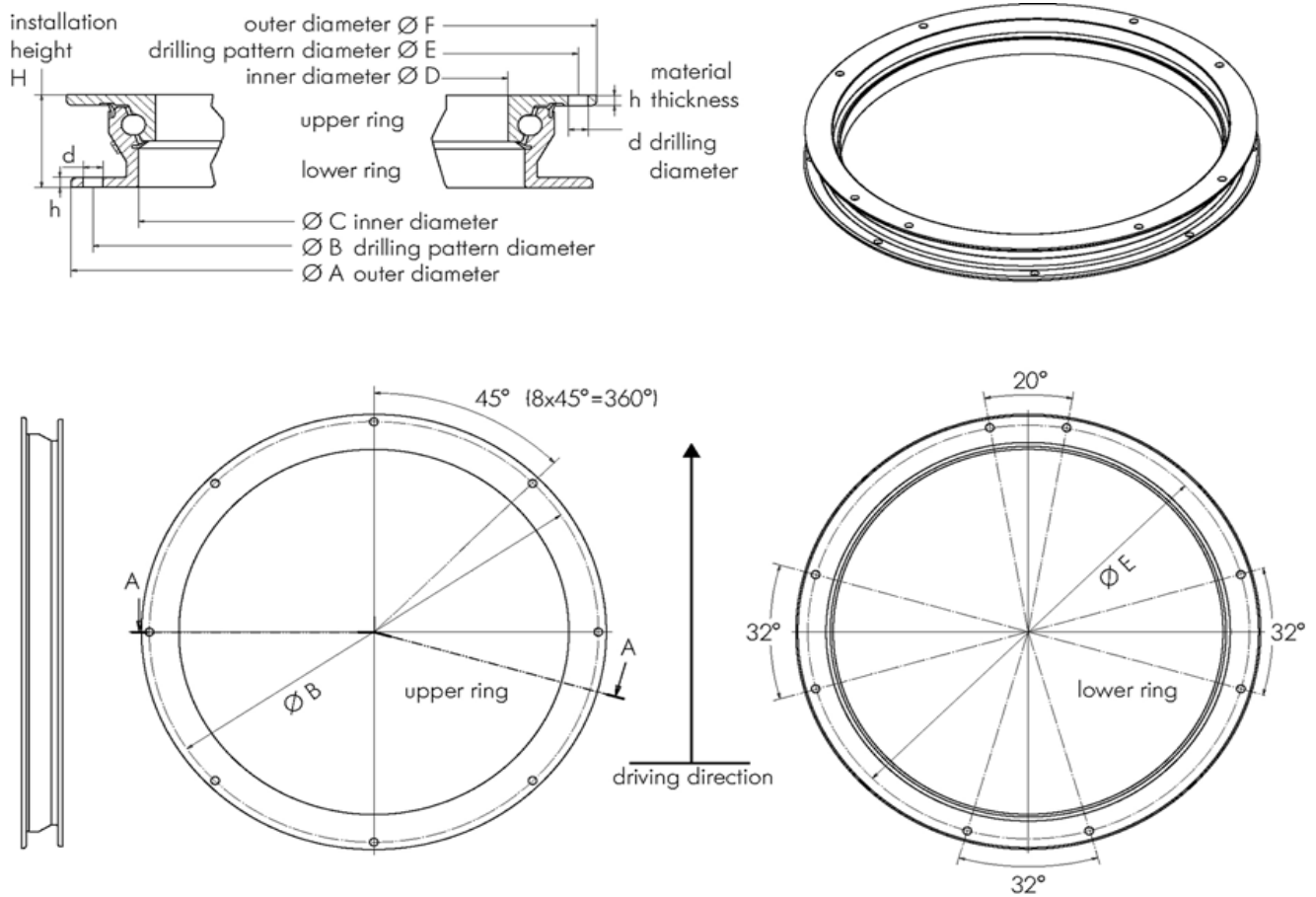

Type	Model	Max. axial load	A	B	C	D	E	F	d	h	H	Weight	Order no.
		t	mm	mm	mm	mm	mm	mm	mm	mm	mm	kg	
BR-W 8	undrilled	8	1000	960	877	846	974	1008	18	10	90	73	662 106 110
BR-W 10	undrilled	10	1000	960	877	846	974	1008	18	10	90	73	662 106 130
BR-W 10-1	drilled	10	1100	1060	977	946	1074	1108	18	10	90	80	662 106 150
BR-W 12-1	drilled	12	1100	1060	977	946	1074	1108	18	10	90	80	662 106 170
BR-W 13-2	drilled	13	1200	1160	1077	1046	1174	1208	18	10	90	87	662 106 190

Technical data

The specifications are nominal dimensions and are subject to the tolerances at our works.

Ball races from SAF-HOLLAND are suitable for the installation on the front axle of 2- and 3-axle drawbar trailers with a max. permissible speed of 105 km/h (65mph). On 2-axle-trailers the specified axle loads can be exceeded by 10%, at speeds below 30 km/h (18 mph) by 20%.

Please request the permitted loads for forced steering semi-trailers, giving details of the vehicle used.

All data apply to use on paved roads and standard road conditions in Western Europe.